

HEAT PUMP OUTDOOR UNITS



SL25XPV

DAVE LENNOX SIGNATURE® COLLECTION

Variable Capacity - Precise Comfort® Technology - 60 Hz

**RESIDENTIAL
PRODUCT SPECIFICATIONS**

Bulletin No. 210813

January 2023

Supersedes November 2022



S40 Smart Wi-Fi Communicating Thermostat (Required - Not Furnished)



SEER2 up to 23.0 / SEER up to 24.0

HSPF2 up to 10.3 / HSPF up to 11.8

2 to 5 Tons

Cooling Capacity - 22,000 to 56,000 Btuh

Heating Capacity - 21,200 to 60,000 Btuh

MODEL NUMBER IDENTIFICATION

SL 25 X P V - 036 - 230 A - 01

Product Tier
SL = Dave Lennox Signature® Collection

Nominal Efficiency

Refrigerant Type
X = R-410A

Unit Type
P = Heat Pump Outdoor Unit

Cooling Stages
V = Variable Capacity Compressor

Minor Revision Number

Ratings Revision Level

Voltage
230 = 208/230V-1ph-60Hz

Nominal Cooling Capacity
024 = 2 tons
036 = 3 tons
048 = 4 tons
060 = 5 tons

FEATURE HIGHLIGHTS

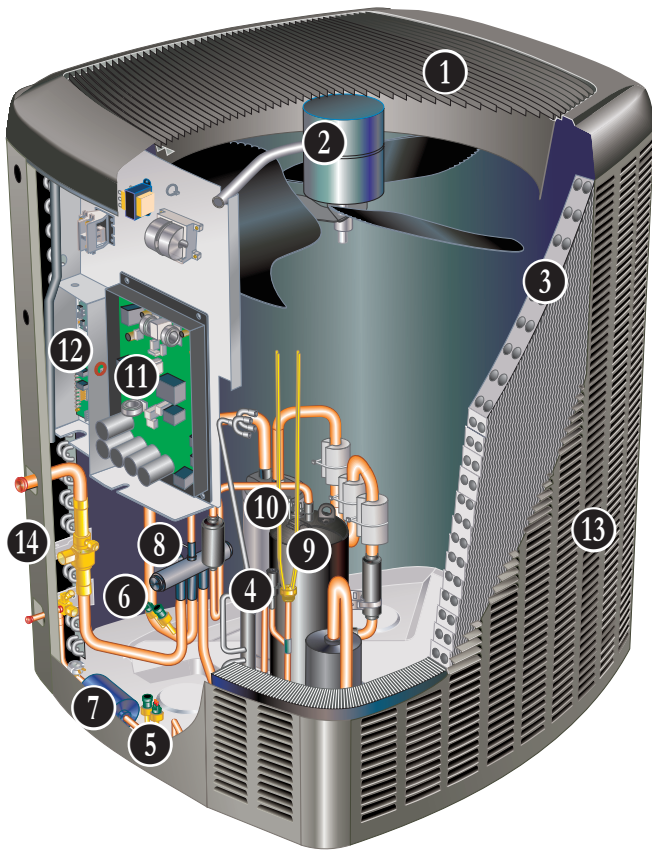

1. Outdoor Coil Fan with Silent Comfort™ Technology Fan Guard
2. Variable-Speed Outdoor Coil Fan Motor with Integrated Control
3. Quantum™ Outdoor Coil
4. Electronic Check/Expansion Valve (EEV)
5. High Pressure Transducer
6. Low Pressure Transducer
7. High Capacity Liquid Line Drier
8. Four-Way Reversing Valve
9. Variable Speed Scroll Compressor
10. Accumulator
11. DC Inverter Control
12. Lennox® Communicating Control
13. SmartHinge™ Louvered Coil Protection
14. Refrigerant Line Connections and Access

NOTE - SL25XPV MODELS CAN ONLY BE MATCHED WITH LENNOX® COMMUNICATING-ENABLED VARIABLE-SPEED INDOOR FURNACES AND AIR HANDLERS.

NOTE - SL25XPV MODELS CAN ONLY BE USED WITH A LENNOX® COMMUNICATING THERMOSTAT.

CONTENTS

Approvals And Warranty	3
Dimensions - Unit	10
Electrical Data	8
Features	3
Field Wiring	9
Installation Clearances	9
Model Number Identification	1
Optional Accessories - Order Separately	8
Required Components - Order Separately	8
Sound Data	9
Specifications	8
TXV Substitution	11
TXV Usage	11

APPROVALS AND WARRANTY

APPROVALS

- AHRI Standard 210/240 certified
- AHRI Certified system match-ups and expanded ratings, visit www.LennoxPros.com
- ENERGY STAR® Certified (certain units)
- Sound rated to AHRI Standard 270 test conditions
- Tested in Lennox' Research Laboratory environmental test room
- Rated According to U.S. Department of Energy (DOE) test procedures
- Unit and components ETL, NEC, and CEC bonded for grounding to meet safety standards for servicing
- ETL certified (U.S. and Canada)
- ISO 9001 Registered Manufacturing Quality System

WARRANTY

- Compressor:
 - Limited ten years in residential installations
 - Limited five years in non-residential installations
- All other covered components:
 - Limited ten years in residential installations
 - Limited one year in non-residential installations

NOTE - Refer to Lennox® Basic Limited Warranty at www.Lennox.com for additional details.

FEATURES

APPLICATIONS

- 2 through 5 ton
- Sound levels as low as 55 dBA
- Single phase power supply
- Applicable to indoor air handlers or gas furnaces with indoor add-on coils
- Shipped completely factory assembled, piped, and wired

NOTE - The SL25XPV heat pump can only be matched with Lennox® Communicating variable-speed indoor furnaces and air handlers.

REFRIGERATION SYSTEM

R-410A Refrigerant

- Non-chlorine, ozone friendly
- Unit is factory pre-charged

NOTE - Total system refrigerant charge is dependent on outdoor unit size, indoor unit size and refrigerant line length.

NOTE - Refer to the unit-mounted charging sticker to determine correct amount of charge required.

1 Outdoor Coil Fan with Silent Comfort™ Technology

- Specially-designed, SilentComfort™ fan guard uses Passive Vortex Suppression to reduce air noise
- Fan guard constructed of corrosion-resistant PVC (polyvinyl chloride) coated steel
- Specially designed fan blades reduce operating sound levels
- Direct drive fan moves large air volumes uniformly through entire condenser coil for high refrigerant cooling capacity
- Vertical air discharge
- Fan service access by removal of fan guard

2 Variable-Speed Outdoor Coil Fan Motor With Integrated Control

- Programmed for variable capacity operation
- Fan speed is directly controlled by communication between the Lennox® communicating outdoor unit control and the Lennox® communicating thermostat
- Inherently protected
- Totally enclosed

3 Quantum™ Coil

- Enhanced aluminum alloy tube/enhanced fin coil
- Superior corrosion resistance
- Lennox designed and fabricated coil
- Ripple-edged aluminum fins
- Aluminum tube construction
- Lanced fins for maximum fin surface exposure
- Fin collars grip tubing for maximum contact area
- Flared shoulder tubing connections
- Factory tested under high pressure
- Entire coil is accessible for cleaning

FEATURES

REFRIGERATION SYSTEM (continued)

- 4 Electronic Check/Expansion Valve (EEV) - Outdoor Unit**
- Designed and sized for heat pump systems
 - Precise refrigerant flow is controlled by signals from the Lennox® Communicating Control
 - Measures pressure and temperature for precise superheat control

Discharge Temperature Switch

- Shuts off unit if operating conditions cause the compressor discharge line temperature to rise above setpoint
- Protects compressor from excessive pressure / temperature
- Automatic reset when temperature drops below setpoint

5 High Pressure Transducer

- Measures pressure in the liquid line
- Pressure readings are used to calculate subcooling values to assist with charging

6 Low Pressure Transducer

- Shuts off unit if suction pressure falls below setting
- Provides loss of charge and freeze-up protection

High Pressure Switch

- Protects the system from high pressure conditions
- Automatic reset

Low Pressure Switch

- Shuts off unit if suction pressure falls below setting
- Loss of charge and freeze-up protection
- Automatic reset

7 High Capacity Liquid Line Drier

- Factory installed in the liquid line
- Traps moisture or dirt
- 100% molecular-sieve, bead type, drier

8 Four-Way Reversing Valve

- Rapid changeover of refrigerant flow direction from cooling to heating and vice versa
- Operates on pressure differential between outdoor unit and indoor coil
- Factory installed

Optional Accessories

Check/Expansion Valve Kits

- Field installed on certain indoor units
- See TXV Usage table
- Chatleff style fitting

Freezestat

- Senses suction line temperature
- Cycles compressor off when suction line temperature falls below its setpoint
- Opens at 29°F and closes at 58°F
- Installs on or near the discharge line of the evaporator or on the suction line

Refrigerant Line Kits

- Refrigerant lines are shipped refrigeration clean
- Lines are cleaned, dried, pressurized, and sealed at factory
- Suction line fully insulated
- Lines are stubbed at both ends

NOTE - The SL25XPV is a variable capacity heat pump utilizing variable speed compressor technology. With the variable speed compressor and variable pumping capacity, additional consideration must be given to refrigerant piping sizing and application.

Refer to the Installation Instructions or Service Literature for Line Set Requirements and Refrigerant Piping Guidelines.

FEATURES

PRECISE COMFORT® TECHNOLOGY

The Variable Capacity Compressor and DC Inverter Control is an integrated system that operates together to reduce overall energy usage when compared to conventional heat pumps.

9 Variable Speed Scroll Compressor

- Operates on a variable frequency determined by the DC Inverter Control to vary capacity based on the cooling load required
- High volumetric efficiency
- Uniform suction flow
- Constant discharge flow
- Quiet operation

Compressor Operation

- Two involute spiral scrolls matched together generate a series of crescent shaped gas pockets between them
- During compression, one scroll remains stationary while the other scroll orbits around it
- Gas is drawn into the outer pocket, the pocket is sealed as the scroll rotates
- As the spiral movement continues, gas pockets are pushed to the center of the scrolls
- Volume between the pockets is simultaneously reduced
- When the pocket reaches the center, gas is now at high pressure and is forced out of a port located in the center of the fixed scrolls
- During compression, several pockets are compressed simultaneously resulting in a smooth continuous compression cycle
- Continuous flank contact, maintained by centrifugal force, minimizes gas leakage and maximizes efficiency
- Compressor is tolerant to the effects of slugging and contaminants

10 Accumulator

- Standard in all models

Compressor Crankcase Heater

- Protects against refrigerant migration that can occur during low ambient operation
- Factory Installed

Compressor Sound Dampening System

- Comprised of a vinyl and polyester composite
- Inner and outer layer sound cover standard on all sizes
- Inner layer sound cover (2 and 3 ton units only)
- All open edges sealed with one-inch wide hook and loop fastening tape
- Rubber dampeners standard on all sizes to reduce sound levels

11 DC Inverter Control

- Converts AC line voltage into filtered variable DC voltage
- Provides continuous compressor operation, while adjusting the capacity according to indoor temperature
- Adjusts compressor output in increments as small as 1%
- The accurate sensing of cooling or heating load prevents frequent changes in capacity and ensures efficient, economical operation
- Power Factor Correction (PFC) circuit monitors the DC bus for high, low and abnormal voltage conditions to protect the compressor
- Integrated noise filter reduces unwanted electromagnetic interference (EMI)
- The inverter reactor (mounted separately) adds inductance to the line between the inverter and the compressor to limit current rise and protect the compressor



FEATURES

CONTROLS

- 12 Lennox® Communicating Control**
- Advanced control communicates information about various operating parameters in the air conditioner to the Lennox® Communicating Thermostats to constantly maintain the highest level of comfort, performance and efficiency available



- **Auto Configuration** - On start-up the control automatically sends a description of the unit to the Lennox® Communicating Thermostat to automatically configure the features available
- Control Features:
 - **Seven-Segment Display** - Shows information about outdoor unit type and capacity and also displays alerts for common fault conditions (electrical and mechanical)
 - **Low Voltage Protection** - Prevents compressor operation when voltage is not within the specified range
 - High and low pressure transducer monitoring with provisions for lockout
 - Five-Strike lockout protection protects compressor
 - Liquid line temperature and sensor monitoring
 - EEPROM storage of all local configurations
 - Non-volatile memory storage of 100 alarm codes with display of last 10 codes for troubleshooting
 - Built-in low-ambient control

NOTE - A 6-pin RAST connector is also provided for outdoor unit wiring connections to the control.

Low Ambient Operation

- **Cooling Mode** - The heat pump can operate down to 0°F outdoor air temperature in the cooling mode.

NOTE - A freeze-stat is recommended for extra protection during low ambient cooling operation.

- **Heating Mode (Low Temperature Protection)**
Outdoor unit will not operate in the heating mode when the outdoor temperature is at or below -4°F
- If the unit is operating and the outdoor temperature drops below -4°F, the unit will continue to operate until the room thermostat is satisfied or the outdoor temperature drops to -15°F

Climate IQ™ Technology

- Optimizes dehumidification settings for specific climates to improve home comfort during cooling or heating operation
- Monitors regional weather conditions and automatically removes excess humidity when necessary

Lennox® Communicating Thermostat Settings:

Cooling Mode

- Three climate settings are available:
 - **Dry** - The system supplies higher indoor airflow at all compressor capacities, increasing efficiency by operating at a higher sensible to total ratio
 - **Moderate** - The system supplies indoor airflow that balances efficiency and comfort
 - **Humid** - The system supplies lower indoor airflow at all compressor capacities, improving humidity removal by operating at a lower sensible to total ratio

Heating Mode

- Two climate settings are available:
 - **Normal** - Heats the home with the highest efficiency
 - **Comfort** - System reduces indoor airflow, increasing supply air temperature
- Climate IQ (Auto) - Dry, Normal, Basic and Humid modes are automatically set based on the difference between the measured relative humidity and the relative humidity setting
- All modes are selected on the Lennox® Communicating Thermostat

TruHeat Performance

- Optimizes system heating performance by providing higher discharge air temperatures, resulting in higher levels of comfort
- More closely resembles the warm discharge air of a furnace and is significantly warmer than typical heat pump systems
- Enabled on the Lennox® Communicating Thermostat (Select "Comfort" in User Settings under "Select Heat Pump Mode")

Outdoor Air Temperature Sensor

- Used with Lennox® Communicating Thermostats
- Sensor allows thermostat to display outdoor temperature
- Sensor is auto-detected when connected to thermostat

FEATURES

CONTROLS (continued)

REQUIRED COMPONENTS

NOTE - The SL25XPV heat pump can only be used with a Lennox® Communicating Thermostat

S40 Smart Wi-Fi Thermostat (part of the Lennox® Residential Communicating Control System)

- Recognizes and connects to all Lennox® Communicating products to automatically configure and control the heating/cooling system (based on user-specified settings) for the highest level of comfort, performance and efficiency
- Recognizes model and serial number information for Lennox® Communicating products to simplify system setup
- Lennox Smart Room Sensors, Lennox Wireless Extenders and Lennox Smart Air Quality Monitor can be added to the system
- Smart home automation compatible with Amazon Alexa®, Google Assistant, Control4® and Building36®
- Sends service alerts and reminders
- Lennox Smart Thermostat App features Wi-Fi remote temperature monitoring and adjustment through a home wireless network apps for smartphones or tablets
- Lennox Smart Technician App allows installer to manage systems in the home
- Service Dashboard features online real-time monitoring and advanced diagnostics of installed Lennox® Communicating systems
- Simple easy-to-use touchscreen allows complete system configuration
- Scheduled maintenance alerts, system warnings and troubleshooting are also displayed on thermostat screen
- Easy to read 7 inch high definition color display (measured diagonally)
- Conventional outdoor units (not Lennox® Communicating) can easily be added and controlled by the S40 Thermostat
- Installer setup screens allow quick and simple system configuration without a manual, Installer can also run tests on complete system or individual components for easy maintenance and troubleshooting
- Serial communications bus (RSBus), with less wiring than a conventional heating/cooling system, allows system communication
- Uses standard 4-wire unshielded thermostat wiring
- High Definition Color Display with Subbase and wallplate furnished for easy installation



CABINET

- Heavy-gauge steel construction
- Louvered steel panels surround unit on all four sides
- Pre-painted cabinet finish
- Control box is conveniently located with all controls factory wired
- Drainage holes are provided in base section for moisture removal
- High density polyethylene unit support feet raise the unit off of the mounting surface, away from damaging moisture

PermaGuard™ Unit Base

- Durable zinc-coated base section resists rust and corrosion

13 SmartHinge™ Louvered Coil Protection

- Steel louvered panels provides complete coil protection
- Panels are hinged to allow easy cleaning and servicing of coils
- Panels may be completely removed
- Interlocking tabs and slots assure tight fit on cabinet



14 Refrigerant Line Connections, Electrical Inlets and Service Valves

- Sweat connection suction and liquid lines
- Located on corner of unit cabinet
- Suction valve can be fully shut off, while liquid valve may be front seated to manage refrigerant charge while servicing system
- Refrigerant line connections and field wiring inlets are located in one central area of the cabinet
- See dimension drawing

Optional Accessories

Snow Guard

- For use in locations where the possibility of heavy snow or freezing rain accumulation may occur
- Heavy gauge powder coated steel guard
- Deflects snow and ice away from the outdoor fan

NOTE - See the Lennox® S40 Thermostat Product Specifications bulletin for more information.

SPECIFICATIONS

General Data		Model No.	SL25XPV-024	SL25XPV-036	SL25XPV-048	SL25XPV-060
Nominal Tonnage			2	3	4	5
Connections (sweat)	Liquid line (o.d.) - in.		3/8	3/8	3/8	3/8
	Vapor line (o.d.) - in.		7/8	7/8	7/8	1-1/8
Refrigerant	¹ R-410A charge furnished		13 lbs. 3 oz.	12 lbs. 10 oz.	16 lbs. 0 oz.	15 lbs. 14 oz.
Outdoor Coil	Net face area - sq. ft.	Outer coil	20.73	20.73	27.21	27.21
		Inner Coil	20.08	20.08	26.36	26.36
	Tube diameter - in.		5/16	5/16	5/16	5/16
	No. of rows		2	2	2	2
	Fins per inch		22	22	22	22
Outdoor Fan	Diameter - in.		26	26	26	26
	No. of blades		3	3	3	3
	Motor hp (W)		1/3	1/3	1/3	1/3
	Cfm - Max. Speed		3800	4300	4300	4300
	Min. Speed		2100	1900	1700	1700
	Rpm - Max. Speed		607	734	861	872
	Min. Speed		406	353	416	385
	Watts - Max. Speed		101	216	229	229
Min. Speed		35	36	34	30	
Shipping Data - lbs. - 1 pkg.			268	275	313	318

ELECTRICAL DATA

Line voltage data - 60hz	208/230V-1ph	208/230V-1ph	208/230V-1ph	208/230V-1ph
² Maximum overcurrent protection (MOCP) amps	25	30	35	35
³ Minimum circuit ampacity (MCA)	20.3	25.6	32.8	32.8
Compressor Inverter Input Current Amps	14	18.2	24	24
Outdoor Coil Fan Motor Full load amps	2.8	2.8	2.8	2.8

REQUIRED COMPONENTS - ORDER SEPARATELY

S40 Smart Wi-Fi Thermostat	22V24	•	•	•	•
⁴ Discharge Air Temperature Sensor	88K38	•	•	•	•

OPTIONAL ACCESSORIES - ORDER SEPARATELY

⁵ Freezestat	3/8 in. tubing	93G35	•	•	•	•
	5/8 in. tubing	50A93	•	•	•	•
⁶ Refrigerant Line Sets (Liq. x Suc. OD x Insulation Thickness - Length)	3/8 x 7/8 x 3/8 - 30 ft.	89J60				
	3/8 x 7/8 x 3/8 - 40 ft.	89J61	•	•	•	
	3/8 x 7/8 x 3/8 - 50 ft.	89J62				
⁷ Snow Guard	3/8 x 1-1/8 x 3/8 - 30 ft.	X0570				•
	3/8 x 1-1/8 x 3/8 - 50 ft.	73P91				
⁷ Snow Guard	40 x 36 in.	X8782	•	•	•	•

NOTE - Extremes of operating range are plus 10% and minus 5% of line voltage.

¹ Refrigerant charge sufficient for 15 ft. length of refrigerant lines. For longer line set requirements see the Installation Instructions for information about line set length and additional refrigerant charge required.

² HACR type breaker or fuse.

³ Refer to National or Canadian Electrical Code manual to determine wire, fuse and disconnect size requirements.

⁴ Used with the Lennox® Communicating Thermostats for optional service diagnostics.

⁵ Freezestat is recommended for Low Ambient operation.

⁶ Refer to the Installation Instructions or Service Literature for Line Set Requirements and Refrigerant Piping Guidelines.

⁷ Adds 11-1/2 inches (292 mm) to unit height

SOUND DATA

1 Unit Model	Octave Band Sound Power Levels dBA, re 10 ⁻¹² Watts Center Frequency - HZ							1 Sound Rating Number (dBA)	2 Estimated Sound Pressure Level at Distance From Unit (dBA at distance in ft.)				
	125	250	500	1000	2000	4000	8000		3	5	10	15	50
024 Min.	48.4	49.5	45.7	43.8	43.2	40.4	34.0	59	52	47	41	38	27
024 Max.	54.3	54.9	54.1	51.1	51.5	52.1	43.0	68	61	56	50	47	36
036 Min.	47.8	44.6	42.9	43.3	35.4	34.6	29.9	55	48	43	37	34	23
036 Max.	57.7	59.5	60.3	58.1	53.6	47.3	36.3	71	64	59	53	50	39
048 Min.	52.2	51.4	48.6	45.9	38.4	34.3	27.8	59	52	47	41	38	27
048 Max.	59.4	62.2	63.6	59.1	56.1	52.1	39.7	74	67	62	56	53	42
060 Min.	54.8	53.5	54.2	53.4	47.9	46.7	37.3	66	59	54	48	45	34
060 Max.	63.7	62.1	65.3	61.0	57.4	54.7	42.2	75	68	63	57	54	43

NOTE - The octave sound power data does not include tonal correction.

¹ Tested according to AHRI Standard 270 test conditions. Sound rating Number is the overall A-Weighted Sound Power Level, (LWA), dB (100 Hz to 10,000 Hz).

² Estimated sound pressure level at distance based on AHRI Standard 275 method for equipment located on the ground, roof, or on side of building wall with no adjacent reflective surface within 9.8 feet. Sound pressure levels will increase based on changes to assumptions. For other applications, refer to AHRI Standard 275.

INSTALLATION CLEARANCES

NOTES -

One of these three sides must be 36 in. (914 mm).
 One of the two remaining sides may be 12 in. (305 mm).
 The remaining side may be 6 in. (152 mm).

Service Clearance – 30 in. (762 mm)

48 in. (1219 mm) clearance required on top of unit

24 in. (610 mm) required between two units

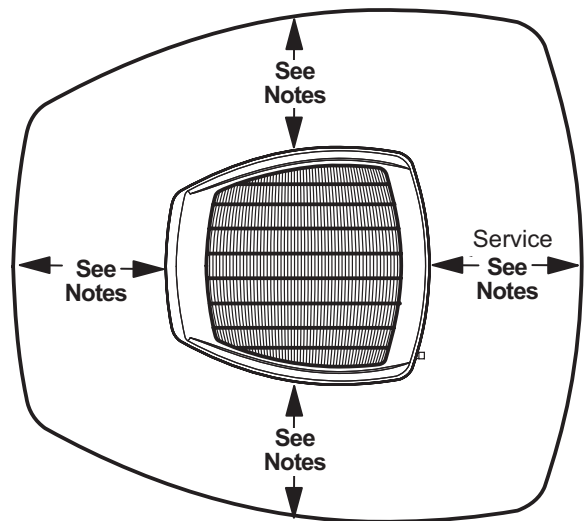

FIELD WIRING

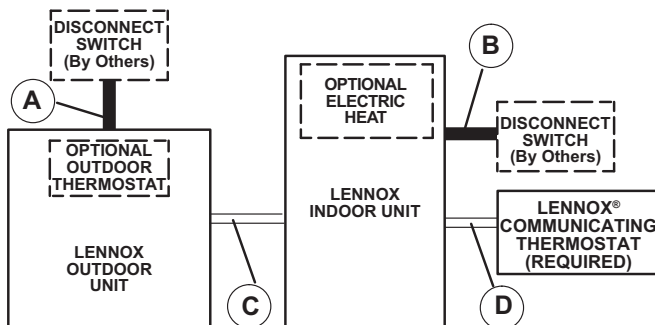

A- Two Wire Power

B- Two or Three Wire Power (size to heater capacity)

C - Lennox® Communicating Thermostat:

- Four Wire, 18AWG (RSBus)

D - Lennox® Communicating Thermostat:

- Four Wire, 18 to 22AWG (RSGBus) standard thermostat cable for terminals (R, C, I+, I-).

NOTE - All wiring must conform to NEC or CEC and local electrical codes.

NOTE - Refer to the S40 Installation Instructions for optional wiring connections for communicating thermostats.

NOTE - Field wiring is not furnished.

DIMENSIONS - UNIT

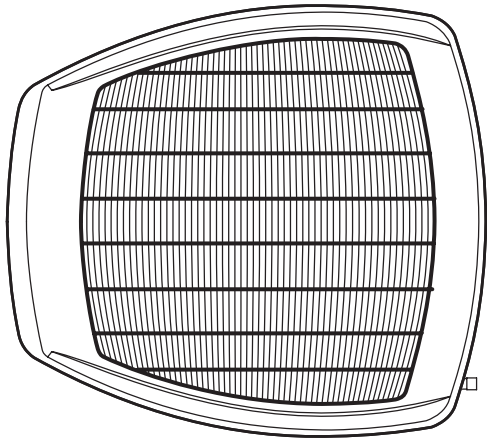

TOP VIEW

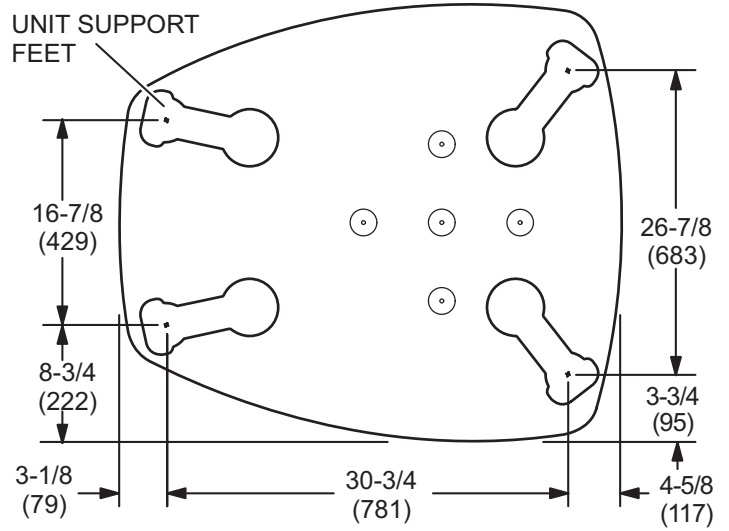

**TOP VIEW BASE SECTION
(Large Base)**

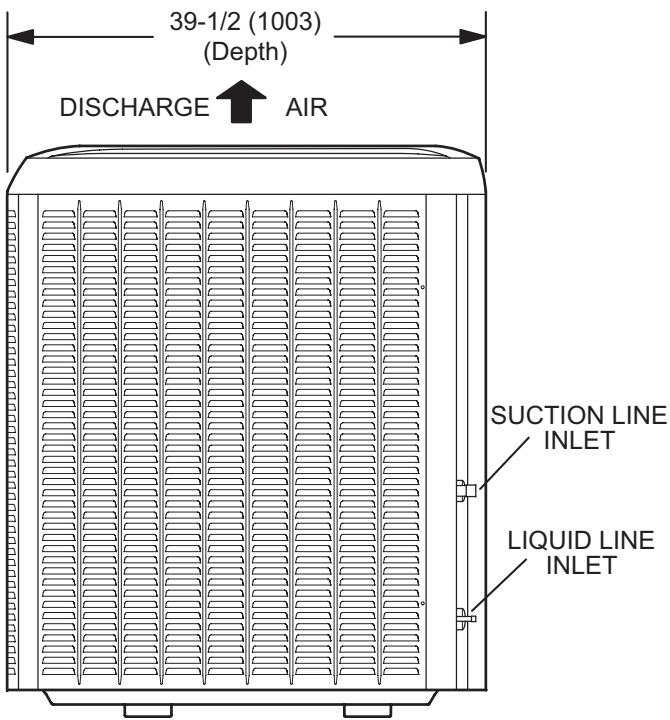

SIDE VIEW

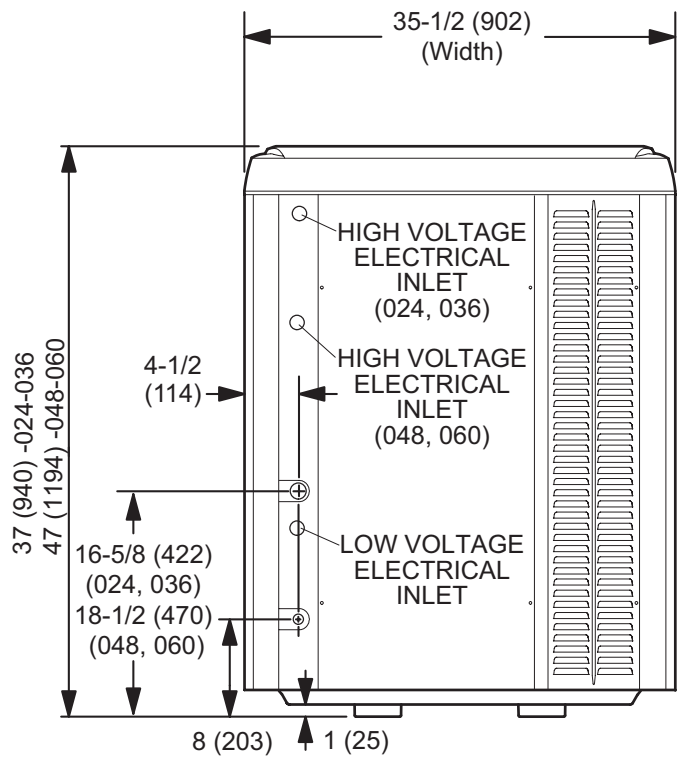

ACCESS VIEW

TXV USAGE

Use this table for C35, CH23 and CR33 Field Installed TXV Match-Ups (if a valid match)

Outdoor Unit Model No.	Order No.
SL25XPV-024	12J18
SL25XPV-036	12J19
SL25XPV-048	12J20
SL25XPV-060	12J20

CX35 and CHX35 coils and all Lennox air handlers are shipped with a factory installed TXV.

C35 coils - Replace the factory installed orifice with the expansion valve listed.

CH23 and CR33 - Use the expansion valve listed.

TXV SUBSTITUTION

A general guide for replacing the factory installed TXV if the indoor unit (coil/air handler) is larger or smaller than the outdoor unit.

Outdoor Unit		Indoor Unit		TXV Furnished	TXV Replacement
Size	Tons	Size	Tons		
024	2	42	3.5	12J20	12J18
024	2	48	4	12J20	12J18
024	2	49	4	12J20	12J18
024	2	50/60	5	12J20	12J18
024	2	51/61	5	12J20	12J18
024	2	60	5	12J20	12J18
036	3	24	2	12J18	12J19
036	3	30	2.5	12J18	12J19
048	4	30/36	2.5/3	12J19	12J20
048	4	36	3	12J19	12J20

TXV Ranges:

12J18 - 1.5 to 2.5 ton systems - Use on 2.5 ton (030) and lower systems.

12J19 - 3 ton systems - Use down to 2 ton (024) systems.

12J20 - 3.5 to 5 ton systems - Use down to 3 ton (036) systems.

AHRI STANDARD 210/240

Cooling or heating capacities are net values, including the effects of blower motor heat, and do not include supplementary heat. Power input is the total power input to the compressor(s) and fan(s), plus any controls and other items required as part of the system for normal operation.

Units which do not have an indoor air-circulating blower furnished as part of the model, i.e., split system with indoor coil only, is established by subtracting from the total cooling capacity 1250 Btu/h per 1,000 cfm, and by adding the same amount to the heating capacity. Total power input for both heating and cooling is increased by 365 W per 1,000 cfm of indoor air circulated.

REVISIONS

Sections	Description of Change
Optional Accessories	Updated Line Sets available.



Visit us at www.Lennox.com

For the latest technical information, www.LennoxPros.com

Contact us at 1-800-9-LENNOX

NOTE - Due to Lennox' ongoing commitment to quality, Specifications, Ratings and Dimensions subject to change without notice and without incurring liability. Improper installation, adjustment, alteration, service or maintenance can cause property damage or personal injury. Installation and service must be performed by a qualified installer and servicing agency.

©2023 Lennox Industries, Inc.